

Possible Approaches to adopt a common methodology to Determine non-ISTS lines on the basis of System Studies

Introduction: The issue of determination of non-ISTS lines carrying Inter-State Power on basis of system studies is complex. Further the issue is to be resolved and also using a common methodology for all RPCs. Some possible approaches along with its advantages / disadvantages are stated in this paper.

Requirements:

As per CERC Regulations the main points are:

- (a) certifying of non-ISTS lines carrying Inter-State Power has to be determined through a process of load flow studies.
- (b) The load flow should show these non-ISTS lines carry more than 50% inter state power (ISP).
- (c) NLDC to adopt a common methodology to vet the lines proposed by RPCs using above criteria.

Approaches:

It is known that the NEW and SR Grids were simulated in full and then truncated up to 400 kV level. The Hybrid method and the POC calculations were done on the reduced network. During the calculations of sensitivities load and generation participation factors were calculated on reduced network.

A natural thought is to calculate Inter-State Power through non ISTS lines by applying the known methods of Average Participation (AP) or Marginal Participation (MP) or Hybrid method (HM). However as argued in this paper, these cannot be applied to determine the Inter State Power (ISP) through non-ISTS lines as they give wrong results/ picture when we limit our objective to determine ISP on non-ISTS lines. However a slightly modified method, which is proposed as Power Displacement method, adopting similar methodology, appears to resolve the issue and is presented.

Approach One: Tracing by Average Participation to find ISP

The AP Approach is familiar to all involved in POC calculations. Here a KCL Tracing is used wherein the out flows are resolved in proportion to the input power flow at a bus.

In Power Tracing Approach or AP method, the power flow on each line can be traced. Once the tracing is over for the network (NEW or SR grids), a matrix stating which lines carry which generator's power can be obtained. Now if one wants to determine ISP power, one may be tempted to shortlist the non-ISTS lines as those state lines which carry more than 50% of non state power. However it is our opinion that this may give erroneous results, as explained below.

Consider a very simple power system given in Figure 1.

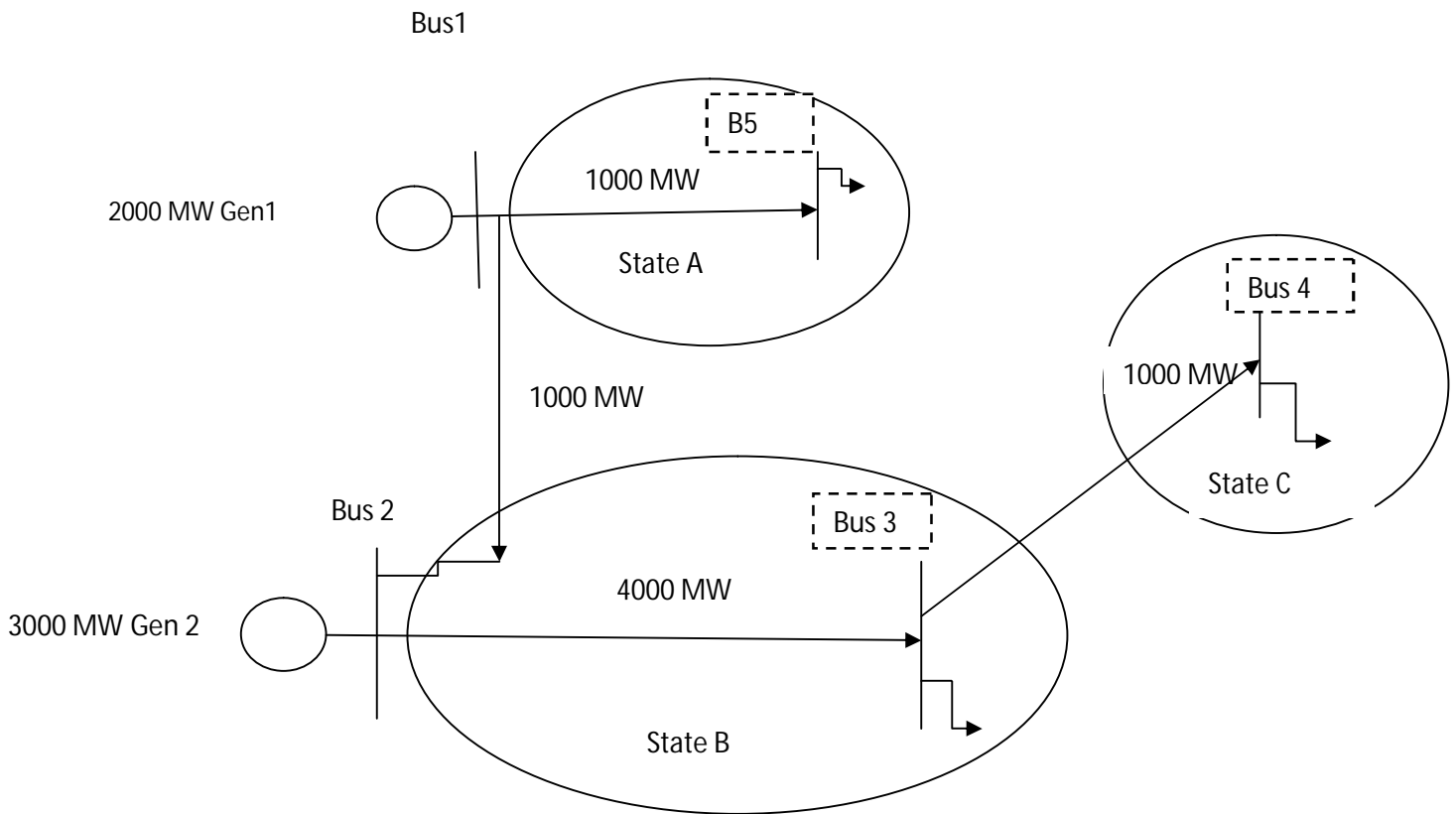

Figure – 1

Gen 1 is connected to Bus 1, (2000 MW) and is assumed to be a non-State generator. Gen 2 is connected to Bus 2, (3000 MW) and is assumed to belong to State B.

Line 1 is in State A, Line 2 in State B and Line 3 connects States B and C. Each load is 1000 MW, 3000 MW and 1000 MW respectively. Each is assumed to be a state line of the respective states.

The results by AP method would show that Line 1, a state owned line is carrying 1000 MW from Gen 1. The participation would show that all this belongs to Central sector Gen 1, and this line may get qualified as a non-ISTS line as 100% power flows in it. But in reality the power is consumed by that State A and is not Inter-State power.

For State B 3000 MW flows from its own generation and 1000 MW is injected into it by Gen 1. Line 2 carries 4000 MW and 1000 MW is displaced by Line 2 to State C. Thus the state B is actually displacing 1000 MW power and line 2 should qualify. But participation would reveal that only 25% (1000/4000 MW) is flowing on it of non-ISTS ISP. And Line 3 carries 100% ISP and qualifies, like line 1, but all that power is consumed by State C and not ISP out of the state.

Though the example may appear at first sight as an extreme one, it underlies one principle that since power flows by displacement, determination of ISP should also look at that factor and mere carrying of non state power does not mean it is a non-ISTS line carrying inter-state power.

Disadvantages:

- 1 Power flows by displacement. As such state lines may appear to carry a lot of non-state power if it has large non-state generators located in it.

Approach 2: Hybrid Method

The Hybrid method can also be applied to the networks. If MP is used then the static network can capture some amount of dynamism. But since the average tracing for this problem itself shows serious drawbacks, the MP would further distort the picture if limitedly applied for this example. As such both AP and HM cannot be applied for the present objective.

Approach 3: Power Displacement Method

The main drawback of the above methods is attempted to be removed if we consider the problem from power displacement view point. It is a well known fact that power flows by displacement.

Consider a State having generation of 10000 MW, injections of 3000 MW and loads of 11000 MW as shown in Figure 2.

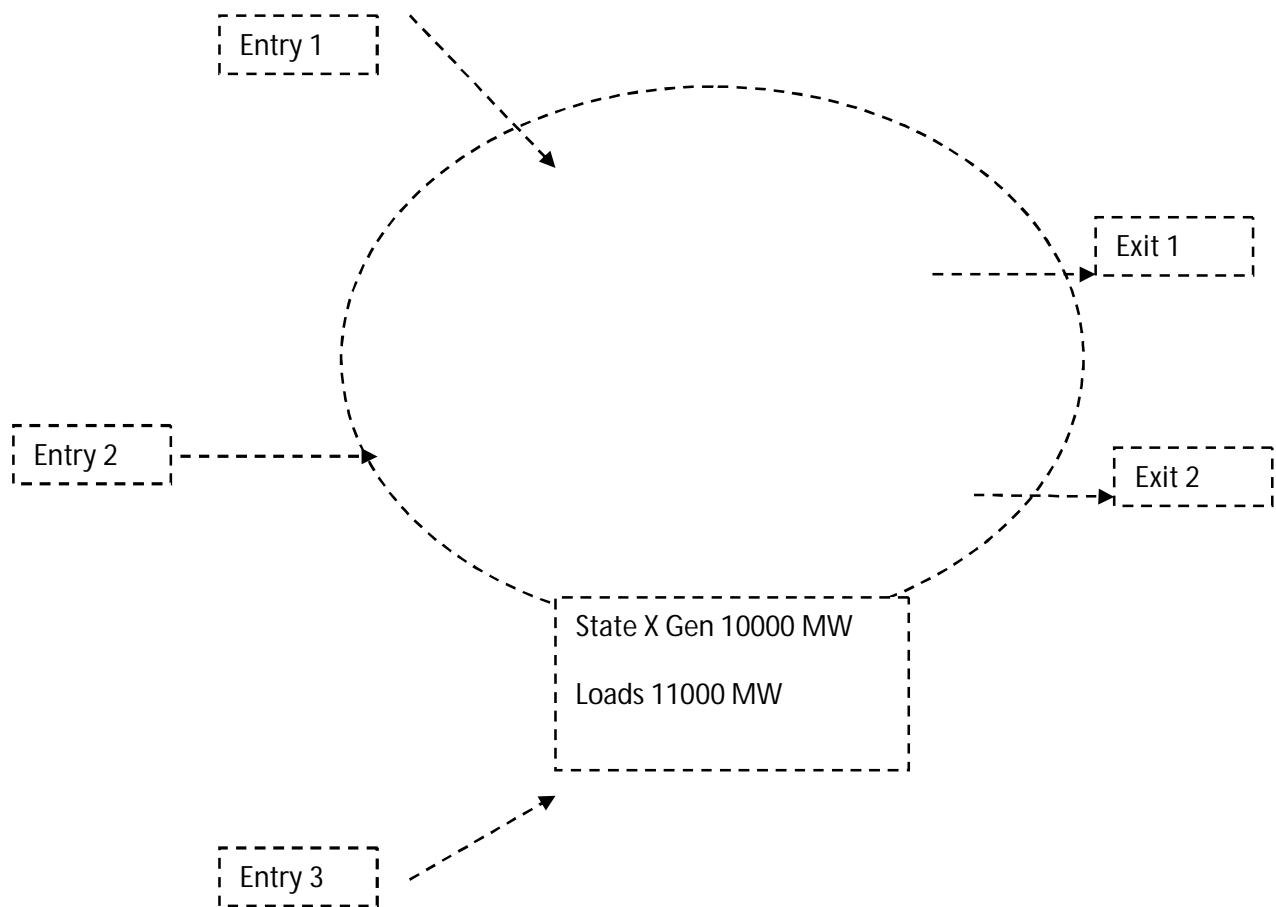

Figure – 2

1. In this approach the identification is carried out state wise.
2. Each state has points where power is injected or 'Entry Points' and power goes out 'Exit Points'
3. For Fig 2, state has an Injection of 3000 MW , its own generation of 10000 MW and load of 11000 MW then 2000 MW flows out.
4. Thus the State displaces power of 2000 MW by its network.
5. So we trace the 2000 MW from the exit points, and see how much each state line carries.
6. Now the state lines could be carrying its own loads as well as transfer ISP of 2000 MW. At or near the exit points, the ratio of ISP to state power would be high. As one moves inward into the state, this ratio would drop down as state is also displacing power to meet its own load. The percentages can be found out, but limited to the exit power.
7. To find out the percentages the same tracing methods AP (MP or HM) can be utilized but limited to tracing the exit powers. Therefore their drawbacks are removed! This way the short listing of lines can be carried out.
8. Each State can then be iteratively worked out.
9. It can be seen that none of the drawbacks shown in Fig-1 is applicable. By the Power Displacement method, State A displaces no power so it cannot have non-ISTS lines carrying ISP. State B carries 1000 MW ISP and 3000 MW own power on Line 2. This line can qualify for first short listing as a non ISTS line carrying ISP. However the ratio of ISP on this line 25% and not on 50%. State C does not displace power out of its state. So Line 3 does not qualify.
10. Thus the method can satisfactorily identify non ISTS lines carrying ISP. An Example is also attached to quantify the calculations within a State using Power Displacement Method. It is proposed to apply the above method to study the results for the power flow on NEW Grid for the last year case and list the lines that qualify for non-ISTS for further necessary action.

Advantages:

1. With this approach we may quantify Inter-state power and non ISTS lines that carry this power.

Example 1: Working out non ISTS lines

Consider a State network shown in Figure-3.

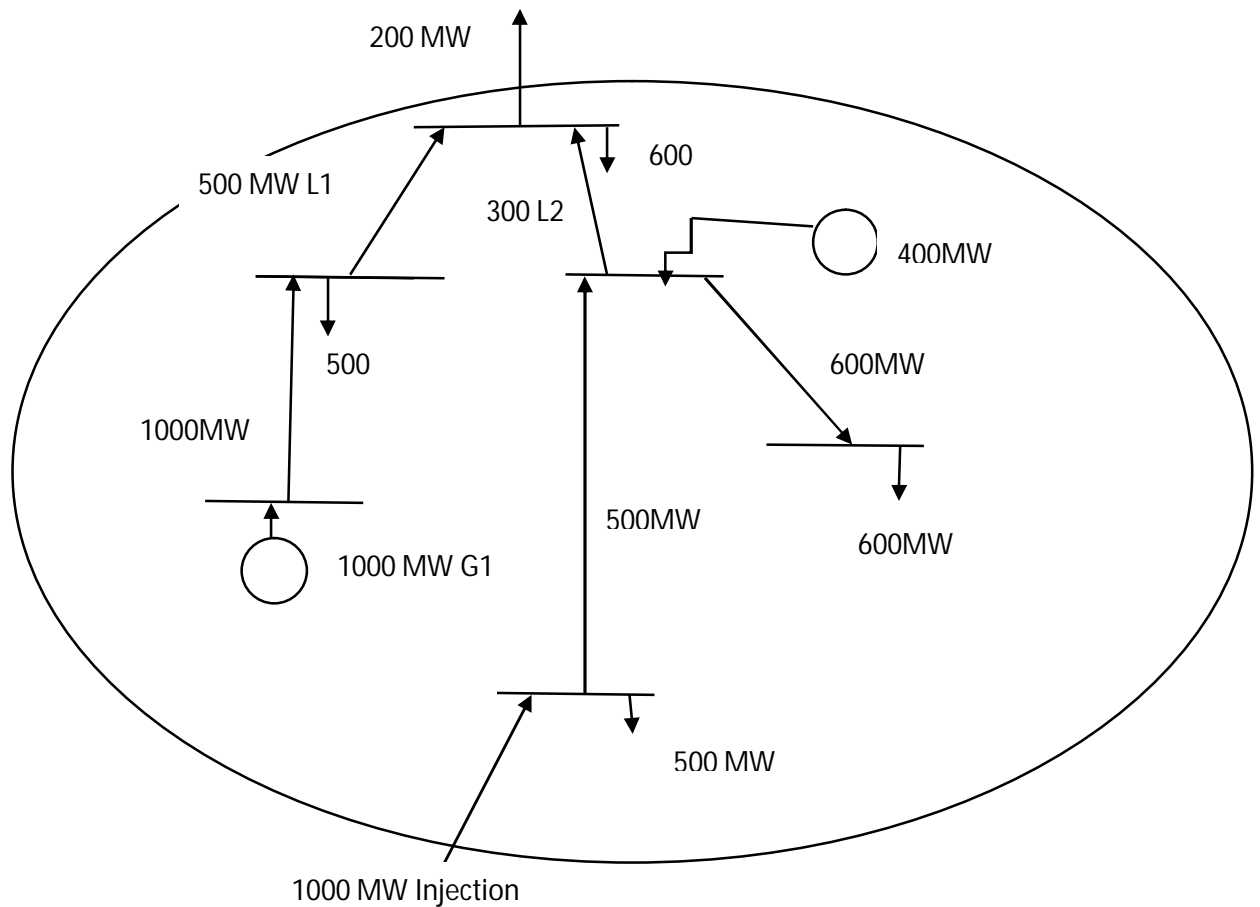

Figure-3 State has an Injection of 1000 MW and exit of 200 MW, its own generation of 1400 MW and load of 2000 MW. So it exports 200 MW after consuming some of the injected power. Using Power displacement method, Exit Point is only one of 200 MW at the top. This is fed from Lines 1 and 2 (500 + 300=800 MW). So these lines carry $(5/8)*200=125$ MW and $(3/8)*200=75$ MW of ISP. In percentage this is 62.5% and 37.5%. At the next bus below, 1000 MW is injected and 500 MW flows on Line 1. So this 1000 MW line is carrying $(125/1000)$ ISP = 12.5%

At the other feed 75 MW from Line 2, below bus, Injection is $(500+400=900)$ MW at the bus. Out of this line carries $75/500 = 150$ MW ISP i.e 15%. Thus only displaced exit powers are accounted. Based on the above non-ISTS lines carrying ISP can be identified.