

EASTERN REGIONAL POWER COMMITTEE

14 GOLF CLUB ROAD, TOLLYGUNGE, KOLKATA-700 033

Phone: 033-24235199/24235005 # Fax : 033-24171358/24221802 # Web : www.eastrpc.org

MINUTES OF THE 17TH COMMERCIAL SUB-COMMITTEE MEETING OF ERPC HELD ON 16.06.2011 (THURSDAY) AT 1100 HRS. AT ERPC, KOLKATA

ITEM NO. 1 CONFIRMATION OF THE MINUTES OF THE 16TH COMMERCIAL SUB-COMMITTEE MEETING HELD ON 23.02.2011

The minutes of the 16th Commercial Committee meeting were circulated vide ERPC letter no. ERPC/COM-I/GEN/2011/1052-82 dated 25.02.2011, on which no comment has been received.

Members may confirm the minutes.

Deliberation/Decision

Members confirmed the minutes of 16th Commercial Sub-Committee Meeting.

ITEM NO. 2 A) PAYMENT OF UI -- PRESENT STATUS

The status of UI payment for 2010-11 and 2011-12 as submitted by ERLDC is enclosed at **Annexure – I & II**. The details are tabulated below:

SL NO	PERIOD	BSEB		JSEB	
		PRINCIPAL	INTEREST (As on 31.05.2011)	PRINCIPAL	INTEREST (As on 31.05.2011)
1	2010 – 11	6.66 Cr	16.75 La	6.29 Cr	12.13 La
2	2011-12 (up to week – 8)	5.79 Cr	9.18 La	(-) 1.79 Cr	5.51 La
	TOTAL	12.44 Cr	25.93 La	4.51 Cr	17.64 La

BSEB and JSEB may indicate the program for payment of total outstanding UI dues for 2010-11 as well as 2011-12.

Members may like to discuss.

Deliberation/Decision

BSEB representative was not present in the meeting. JSEB representative assured that they would liquidate their outstanding dues within a week

B) RECONCILIATION OF UI POOL ACCOUNT

As intimated by ERLDC, the statement of reconciliation of UI Account for the period from April'10 to March'11 was sent to all constituents on 29.04.2011 for checking at their end and confirmation. WBSETCL, NTPC, NHPC, NERLDC & SRLDC have sent their confirmation. The above confirmation is yet to be received from other constituents.

Members may confirm the same at the earliest.

Deliberation/Decision

ERLDC informed that DVC has reconciled the UI account. All constituents informed that they would send their confirmation within a week. It was unanimously agreed that if confirmation was still pending from any constituents by 29.06.2011 it will be deemed to be taken as confirmed.

D) REACTIVE ENERGY CHARGES – PRESENT STATUS.

As per ERLDC, the updated position of Receipt/Payment of Reactive Energy Charges in the pool as on 31.05.2011 (considering bill up to 22.05.2011) is indicated in **Annexure – III**. Out of this amount Rs. 2.26 Lac has been paid to POSOCO for further disbursement to M/S AREVA for imparting training to ER Constituents. The above amount is paid on 10.05.2011.

Members may please note.

Deliberation/Decision

Members noted the status of Reactive Energy Charges account.

ERLDC informed that one training of SCADA EMS was completed. Second training is scheduled to be held from 20.06.2011.

ERLDC also informed that training on “Black Start & Restoration Procedures” would be organized on 24.06.2011 jointly by ERLDC and ERPC.

E) TRANSFER OF UI (PRINCIPAL & BANK INTEREST) FROM ERLDC UI POOL ACCOUNT TO POWER SYSTEM DEVELOPMENT FUND (PSDF)

As submitted by ERLDC, an amount of Rs.2.02 Crores on account of capping and Rs. 2.04 Crores on account of surcharge for the year 2010 – 11 have been transferred to PSDF on 20.05.11. The status of fund transferred to PSDF so far is enclosed in **Annexure IV**.

This is for information to the members.

Deliberation/Decision

Members noted.

ITEM NO.3 ISSUES RAISED BY ERLDC

A. NON RECEIPT OF SEM DATA

JSEB

Since 22.02.10, SEM readings from JSEB substations for JSEB tie lines are not being received at ERLDC. The matter had been discussed in various forum of TCC/ERPC wherein it was intimated by JSEB that they are taking expeditious action in this regard. Nothing has been done so far and entire computation is being done considering the meter readings of other ends.

JSEB is requested to look into the matter and ensure sending of data at ERLDC.

Deliberation/Decision

- JSEB informed that contract for collection and transfer of meter data to ERLDC has already been awarded.
- JSEB representative assured that ERLDC would start receiving data by the end of this month.

B. METERING ARRANGEMENTS OF VARIOUS IPPS

MEJIA – B POWER STATION

In the 16th ERPC meeting it was decided that Mejia – B shall be considered as a separate control area and its scheduling shall be done by ERLDC as per the provisions of IEGC. ERLDC informed that the metering requirement of the power station has already been examined at their end and proposed metering scheme of Mejia - B has also been

forwarded to DVC for further necessary action. It was informed to DVC by ERLDC that DVC/MEJIA shall interact with POWERGRID, ERTS-II for installation of additional meters (check and standby) the details of which are given in the diagram in **Annexure—V**.

One nos of SEM (as Check meter) each at Mejia-B end of both the 400 KV outgoing Feeders, 02 nos of SEMs (as Standby) at EHV side of GTs, 02 nos of SEMs (as standby) at EHV side of Station transformer is required to be installed. Thus total 06 nos of SEMs are required to be installed.

DVC is requested to inform the latest status.

Deliberation/Decision

- DVC informed that main meter was in service.
- ERLDC informed that two numbers of check meters and two numbers of standby meters are required to be installed.
- DVC assured to provide the latest status of installation of meters in two days time.

C. SEL (STERLITE ENERGY LIMITED)

The metering requirement at Sterlite has been re-examined in a meeting with ERPC, ERLDC & SEL at Jharsugda on 23.05.2011. It has been decided in the meeting that Special Energy meter should be installed on HV Side as well as LV Side of each ICT, CPP to Budhipadar connection at VAL end, which has to be arranged by SEL. Further 02 nos of L&T make ABT meter is required to be installed on the VAL-Budhipadar feeder at Budhipadar end. Sterlite intimated that they are going to synchronise U # 3 by 3rd/4th week of May'2011. Therefore, for UI energy accounting purpose, 02 nos of SEM are required to be installed (One SEM each at EHV side of GT & Station transformer). Thus total 08 nos of SEMs are required to be installed at Sterlite.

The L&T make ABT meters shall be provided and installed by POWERGRID, ER-II. POWERGRID shall also arrange for 02 no DCDs to enable downloading of data from these meters. SEL shall arrange to send all the ABT meter readings on weekly basis (by every Monday) to ERLDC, through email. SEL will provide the switchyard SLD, protection & metering scheme details to SLDC/ERLDC/ERPC within a week.

STERLITE is requested to expedite installation of these meters.

Deliberation/Decision

SEL assured that the meters for Unit # 3 was in place and data will be available to ERLDC within a week.

D. 66 KV RANGIT – RABANGLA LINE

During the last standing committee meeting approval was accorded for converting 66 KV Rangit –Melli line to (i) 66 KV Rangit – Rabangla line and (ii) 66 KV Melli – Rabangla line. With the changed configuration the tie line now should be considered as 66 KV Rangit – Rabangla line instead of 66 KV Rangit –Melli line. Sikkim/Powergrid may initiate action of shifting of Melli end meter to Rabangla for 66 KV Rangit – Rabangla Line and Sikkim may arrange for sending of Rabangla end data for UI computation purpose.

The matter discussed in 16th Commercial sub-committee but no action has yet been taken.

ERLDC may explain.

Deliberation/Decision

PGCIL representative informed that they would sort out the matter in coordination with Sikkim.

E. INSTALLATION OF METER AT PPSP

400 KV PPSP – Durgapur line was made LILO at Bidhannagar in WBSETCL. With this, the new Tie line became as 400 KV Bidhannagar-Durgapur. Special energy meter had already been installed at Durgapur, which is being used for accounting purpose. However at present there is no ABT meter installed at Bidhannagar end. As per CEA metering regulation 2006 and its amendments, one no. of SEM is required to be installed also at Bidhannagar end of Bidhannagar – Durgapur line and the same end data is required to be sent at ERLDC for UI computation purpose.

ERLDC may please explain.

Deliberation/Decision

- WBSEDCL informed that they would inform their counterpart of WBSETCL to take up the matter with PGCIL.

- WBSUEDCL representative assured that the matter would be sorted out before ensuing TCC/ERPC meetings.

F. OPENING OF NEW ACCOUNT

Consequent to the formation of Power System Operation Corporation (POSOCO) as a wholly owned subsidiary company of POWERGRID, new bank accounts have been opened as detailed below in IDBI Bank, Specialised Corporate Branch, Kolkata.

Bank : IDBI Bank, Specialized Corporate Branch,
Kolkata
IFSC Code : IBKL0000135
Type of Account : Current Account
Bank Tel No. : 033 – 66338889/66337739
Bank Account Details :

Power System Operation Corporation Ltd.
– ERPC UI A/C : 0135103000005029

Power System Operation Corporation Ltd.
– ERPC Reactive A/C : 0135103000005043

Power System Operation Corporation Ltd
– ERPC IRE A/C : 0135103000005036

ERLDC Short-term Open Access A/C : 0135103000005012

Henceforth the payments are required to be made in the new accounts with immediate effect.

Members may kindly note and get it complied in their respective organizations.

Deliberation/Decision

Members noted.

G. INFORMATION REGARDING CT/PT RATIO

The meter details along with the CT/PT ratio has been uploaded at ERLDC website (www.erlhc.org). Constituents were requested to verify the same at their end and intimate ERLDC if any discrepancy is observed by return FAX / mail. Except two – three locations, no intimation is received from the constituents.

Constituents are once again requested to intimate if there is any discrepancy is observed or not.

Deliberation/Decision

Members assured to check the CT/PT ratios and inform ERLDC of any change to be made in future.

H. OPENING OF LC BY ER CONSTITUENTS FOR UI PAYMENTS

As per the Unscheduled Interchange charges and related matters (Amendment) Regulations, 2010 issued by CERC vide notification No. L-1(1)/2009-CERC dated 28th April, 2010 (effective from 03.05.10)

Quote

All regional entities which had at any time during the previous financial year failed to make payment of Unscheduled Interchange charges including Additional Unscheduled Interchange charges within the time specified in this regulations shall be required to open a Letter of Credit (LC) equal 110% of its average payable weekly UI liability in the previous financial year, in favor of the concerned RLDC within a fortnight from the date these Regulations come into force.....

.....Provided further that LC amount shall be increased to 110% of the payable weekly liability in any week during the year, if it exceeds the previous LC amount by more than 50%.

Unquote

The LC amount to be opened by BSEB & JSEB is tabulated in **Annexure - VI**. ERLDC has already intimated the concerned constituents through individual letters.

BSEB and JSEB may inform the latest status.

Deliberation/Decision

BSEB representative was not present in the meeting. It was decided to refer this issue to TCC.

I. NON-RELEASE OF PAYMENT TOWARDS SERVICE CHARGES FOR MAINTENANCE OF EMS/ SCADA SYSTEM –FIFTH AND SIXTH QUARTERS’ BY FOLLOWING CONSTITUENTS:

LTSA(Long term Service Agreement) contract for EMS/SCADA system installed at all control centres (ERLDC ,WBSETCL, OPTCL, DVC, JSEB, BSEB & Sikkim) was awarded to M/s Areva India T & D Ltd. on 15th January 2010 by ERLDC. As per MOU between ERLDC and constituents, constituents have to pay advance quarterly charges for each quarter. During the 8th SCADA O & M meeting held at ERLDC, Kolkata on 25th Jan’11, ERLDC impressed upon the constituents to make quarterly payment of maintenance charges to ERLDC within stipulated

time, in order to facilitate timely payment to M/s Areva. All the constituents except BSEB, OPTCL & Sikkim have paid the AMC charges so far. As on 01/06/2011 following are the dues against BSEB, OPTCL & Sikkim:

Sikkim			
S.N.	Quarter	Bill Amount	Due Date
1	05(From : 18th Jan , 2011 To : 17th Apr , 2011)	49432	17.01.11
2	06 (From : 18th Apr, 2011 To : 17th Jul , 2011)	49432	17.04.11
		Rs. 98,864	
BSEB			
S.N.	Quarter	Bill Amount	Due Date
1	06 (From : 18th Apr, 2011 To : 17th Jul , 2011)	1486541	17.04.11
		Rs.14.86 Lacs	
OPTCL			
S.N.	Quarter	Bill Amount	Due Date
1	06 (From : 18th Apr, 2011 To : 17th Jul , 2011)	3785575	17.04.11
		Rs. 37.86 Lacs	

Total Outstanding amount is **Rs. 53.70 Lacs**

BSEB, Sikkim and OPTCL are requested to submit their plan of liquidation of their outstanding amount as above.

Deliberation/Decision

- Sikkim assured that they will liquidate their dues within one month.
- OPTCL informed that the change over from ERLDC to POSOCO had caused some delay. They have taken up the matter and it would be sorted out soon and payments will be made within a month.

ITEM NO.4 STERLITE ENERGY LIMITED (SEL) --SCHEDULING,LTA, ETC.

ERLDC vide their letter No-ERLDC/POSOCO/REA/2011/ dated 25.05.2011 have informed that power from SEL is being scheduled from 01.04.2011 against their LTA of 400 MW. This has been given effect from April-11 REA onwards. As a result, other ER constituents have been getting a relief of around Rs. 3 Crores on account of ER transmission charges.

This is for information of the members.

Deliberation/Decision

Members noted.

ITEM NO.5 DECLARATION OF COD OF PGCIL ELEMENTS IN EASTERN REGION

A. 400 KV D/C BIHARSHARRIF –KODARMA TL ASSOCIATED WITH START-UP POWER TO DVC.

POWERGRID has declared the COD of 400 KV D/C BIHARSHARRIF – KODARMA transmission line associated with start-up power to DVC with effect from 01.06.2011(Ref: PGCIL Letter ER-I/PT/EDO/951 dated 17.05.11).

Powergrid is requested to provide relevant information in approved format.

Members may discuss.

Deliberation/Decision

Powergrid provided the requisite information which is attached in **Annexure--VII**. Members recommended to TCC for acceptance of COD of the above element.

B. 160 MVA 220/132 KV ICT-II AND ASSOCIATED 220KV & 132 KV BAYS AT BARIPADA.

In the meeting Powergrid informed that the above element has been declared commercial w.e.f 01.04.2011 and requested members to recommend to TCC for acceptance of the same.

Deliberation/Decision

Powergrid provided the requisite information which is attached in **Annexure--VII**. Members recommended to TCC for acceptance of COD of the above element.

ITEM NO.6 AGENDA POINTS OF DGPC, BHUTAN.

1. Discrepancy in joint energy meter reading of 400 KV feeder-I at Binaguri substation

During the JMR on 1st March, 2011, it was observed that energy received at Binaguri through 400 KV feeder-1 was 12.501091 MU

whereas the reading at Tala end was 16.201000 MU reportedly due to CVT failure.

THP requests PGCIL and others that such discrepancies may please be avoided in future.

Deliberation/Decision

PGCIL informed that the matter has been resolved with Tala Authorities.

2. Testing of Energy Meters

As per PPA signed between PTCIL and Royal Govt. of Bhutan, SEMs and conventional digital meters shall be tested by standard procedure at least once in 12 months by respective owners.

It has been reported that meters at Binaguri end have not been tested since their installation.

THP requests that these meters be tested every year which could be mutually witnessed by THP and Binaguri S/S PGCIL representatives.

Deliberation/Decision

PTC will initiate action in coordination with Tala Authorities and PGCIL and mutually agreed dates would be intimated to ERPC secretariat. ERPC secretariat would write to PTC in this regard.

3. Replacement of check meter of 400 KV Tala-Binaguri Feeder-4

The L&T make check meters installed at Tala Power House had failed one month after their installation in 2007. Despite several requests to PTC and PGCIL no action has been initiated.

PTC and PGCIL are requested to take immediate action to replace/repair the meter.

Deliberation/Decision

PTC was requested to take up the matter in coordination with Tala Authorities and PGCIL and resolve the issue at the earliest.

ITEM NO.7 SCHEDULE OF INFORM POWER FROM DVCS UPCOMING GENERATING UNITS AT CTPS (UNIT #7 &8) AND MEJIA PH-II (UNIT #7)-----ADDITIONAL AGENDA BY DVC

Deliberation/Decision

This agenda was withdrawn by DVC.

ITEM NO.8 ABNORMAL HIKE IN FPA OF NTPC FARAKKA, KAHALGAON I&II AND TALCHER, ETC-----ADDITIONAL AGENDA BY JSEB

Deliberation/Decision

This agenda was withdrawn by JSEB.

ITEM NO.9 ENHANCEMENT OF LC BY BSEB-----ADDITIONAL AGENDA BY NHPC

In the meeting NHPC informed that BSEB has not enhanced their LC limit despite several reminders.

Deliberation/Decision

As BSEB representative was not present in the meeting this issue could not be taken up.

ITEM NO.10 INTEGRATED PLANNED MAINTENANCE OF TALCHER STAGE-I & II STPS-----REFERRED BY LAST ERPC

Deliberation/Decision

It was informed that the meeting of the Sub-Committee constituted by ERPC to examine the operational issues of Kahalgaon Stage I&II is scheduled on 18.06.2011 at ERPC. It was decided that the above issue would be taken up once the recommendation of Sub-Committee is finalized and accepted by ERPC.

ITEM NO.11 COAL ARRANGEMENT OF FARAKKA STPS UNIT #6-----REFERRED BY LAST ERPC

Deliberation/Decision

It was informed that the meeting of the Sub-Committee constituted by ERPC to examine the operational issues of Kahalgaon Stage I&II is scheduled on 18.06.2011 at ERPC. It was decided that the above issue would be taken up once the recommendation of Sub-Committee is finalized and accepted by ERPC.

ITEM NO.12 REPLACEMENT OF ENERGY METER OF 400 KV TALA-BINAGURI FEEDER 2 & 3-----ADDITIONAL AGENDA

DGPC vide their letter no-DGPC/THP/EE(OD)/T-11/2011/771 dated 09/06.2011 to Sr Vice President, PTC with a copy to S.E. (commercial), ERPC have informed that they have replaced main meters of 400 KV Tala

Binaguri II & III (Tala end) which were of Landis and Gyr make with L&T make meters.

This is for information of members

Deliberation/Decision

Members noted

ITEM NO.13 LESS REGISTRATION AT 132 KV MAITHON-JAMTARA TIE FLOW FROM 23.09.2007 TO 03.12.2007-----AGENDA BY DVC

At the meeting convened at ERPC, Kolkata on 18.01.2011 between JSEB, DVC and ERPC a model of calculation was decided, which was agreed unanimously by JSEB and DVC. DVC had intimated that the formula proposed in the meeting dated 18.01.2011 has been approved by DVC management.

In the last ERPC meeting DVC and JSEB had agreed to resolve this issue. However, JSEB management has not yet formally approved the formula.

JSEB is requested to accept the formula and settle the payments.

Deliberation/Decision

Members referred this to TCC for further deliberation

ITEM NO.14 SOFTWARE FOR PREPARATION OF MONTHLY TRANSMISSION ACCOUNTS AS PER CERC (SHARING OF IST CHARGES & LOSSES) REGULATIONS, 2010

Deliberation/Decision

Mr. Kumar Ravi, Managing Director of M/s CyBuzz SC familiarized the members with their RATS (Regional Account for Transmission System) software, which they have developed to calculate monthly transmission account as per CERC (Sharing of IST Charges & Losses) Regulations, 2010.

He intimated that the price of the software for NRPC had been Rs.5 Lacs plus taxes. The company offered a discount of 20% to ERPC for the above software provided no customization is required.

CyBuzz SC was asked to furnish written confirmation of its offer.

Members recommended to TCC for consideration of proposal of procurement of RATS software from M/s CyBuzz SC at a cost of approximately 4 Lacs plus taxes as applicable, by utilizing the ERPC FUND.

ITEM NO.15 SHARING OF ISTS CHARGES AND LOSSES AS PER NEW REGULATIONS OF CERC.

A) IDENTIFICATION OF NON-ISTS LINES CARRYING INTER --- STATE POWER

Deliberation/Decision

SE (Commercial), ERPC, informed that as per latest order of CERC dated 04.04.2011 and minutes of 4th validation committee for the year 2011-12, only those lines would be considered whose transmission charges was being shared prior to 15.06.2010. Thus the consolidated list of non-ISTS ER lines carrying inter-state power sent by ERPC Sectt was rejected by Implementing Agency.

Consequently, ERPC Secretariat has intimated NLDC that 220 KV Budhipadar Ckt-I&II should be included as per the new order.

For identification of non-ISTS lines for inclusion in the year 2012-13, ERPC Secretariat wrote to the constituents for submission of non-ISTS lines. In response, Bihar and Gridco submitted the list. Responses from the other constituents are awaited.

In the last Commercial Committee meeting, the remaining constituents were requested to furnish the list by 23.06.2011. To this, JSEB, WBSEDCL/WBSETCL, Sikkim confirmed that they would submit a list of their lines carrying inter-state power by next Thursday (23.06.2011).

After deliberation it was decided that ERLDC would carry out system study to identify the non-ISTS lines for Eastern Region and make a presentation in the TCC meeting for deliberation and acceptance.

B) INCREASE OF TRANSMISSION CHARGES FOR ER CONSTITUENTS---AGENDA SUBMITTED BY GRIDCO, JSEB.

Deliberation/Decision

GRIDCO and JSEB intimated that their transmission charges will go up substantially if the PoC methodology of sharing of transmission charges and losses is made effective. DVC also informed that in their case also the rise of transmission charges is substantial.

It was decided that the constituents should approach the CERC and NLDC for clarification regarding the spurt in transmission charges as per the PoC methodology.

THE MEETING ENDED WITH A VOTE OF THANKS TO THE CHAIR

Annexure - I

SUMMARY OF UI RECEIPT AND PAYMENT STATUS

BILL UPTO 27.03.2011 (Week - 52 of 2010 - 11)
Last Payment Disbursement Date - 09.05.11

Figures in Rs. Lakhs

CONSTITUENTS	Receivable	Received	Payable	Paid	Outstanding
WR	2427.61745	2427.83708	103102.62970	103102.84933	0.00000
SR	13216.66971	13216.66971	5032.73215	5032.73215	0.00000
NER	3077.16459	3043.94511	14575.64242	14542.42299	0.00005
NR	120147.02952	120171.33321	375.58654	399.89023	0.00000
BSEB	6590.15778	5703.80937	8973.47389	8752.76517	665.63969
JSEB	2951.65982	1314.61105	19835.76128	18828.20985	629.49734
DVC	42809.38169	42827.86304	482.11664	500.59799	0.00000
GRIDCO	7563.58258	8756.82839	28337.61818	29530.86399	0.00000
WBSETCL	10110.33035	10541.40680	13872.71756	14303.79400	-0.00001
SIKKIM	922.19002	627.78336	2063.95000	1769.54334	0.00000
NTPC	299.20215	299.26116	3512.05681	3512.11582	0.00000
NHPC	1.83443	1.83443	1434.03509	1434.03509	0.00000
MPL	81.03942	81.03942	0.00000	0.00000	0.00000
STERLITE	0.00000	0.00000	3686.15581	3686.15581	0.00000
Pool Balance	0.00000	0.00000	1177.70540	1177.70540	0.00000
Additional UI charge	2320.58622	1495.93011	585.78482	0.00000	824.65611
Transfer to IRE	0.00000	0.00000	514.91659	581.52578	66.60919
TOTAL	210197.85951	209014.22	207562.88288	207155.20694	

% Realization 99.4368937 **As on 09.05.11**

Receivable: Receivable by ER POOL Payable Payable by ER POOL
 Received Received by ER POOL Paid Paid by ER POOL
 "- ve" Payable by ER pool "+ ve" Receivable by ER pool

Annexure - II

SUMMARY OF UI RECEIPT AND PAYMENT STATUS

BILL UPTO 22.05.2011 (Week - 08 of 2011 - 12)

Last Payment Disbursement Date - 03.06.11

Figures in Rs. Lakhs

CONSTITUENTS	Receivable	Received	Payable	Paid	Outstanding
WR	0.00000	0.00000	12743.54475	10451.51527	-2292.02948
SR	1139.05952	715.53208	533.57162	388.05252	278.00834
NER	1198.69489	642.59237	926.62236	926.62236	556.10252
NR	7422.50960	6069.62996	223.06118	0.00000	1129.81846
BSEB	1288.50616	0.00000	709.95959	0.00000	578.54657
JSEB	886.90253	0.00000	1065.87921	0.00000	-178.97668
DVC	13614.84348	12980.29129	0.00000	0.00000	634.55219
GRIDCO	177.63047	177.63047	2019.91886	940.15611	-1079.76275
WBSETCL	78.29638	78.29638	9399.56282	8704.49075	-695.07207
SIKKIM	28.47778	28.47778	1871.34877	1432.73508	-438.61369
NTPC	346.17976	152.17050	481.26706	481.26706	194.00926
NHPC	0.00000	0.00000	327.12115	232.16656	-94.95459
MPL	24.81888	23.01216	0.00000	0.00000	1.80672
STERLITE	5152.13042	3516.57449	753.01417	753.01417	1635.55593
Pool Balance	0.00000	0.00000	-155.76031	0.00000	155.76031
Additional UI charge	340.14218	175.19505	0.00000	0.00000	164.94713
Transfer to IRE	0.00000	0.00000	-0.03336	0.00000	0.03336
TOTAL	31358.04987	24384.21	30899.07787	24310.01988	

% Realization 77.7605992 As on 03.06.11

Receivable:

Receivable by ER POOL

Payable

Payable by ER POOL

Received

Received by ER POOL

Paid

Paid by ER POOL

"- ve" Payable by ER pool

"+ ve" Receivable by ER pool

**STATUS OF REACTIVE CHARGES IN ER REACTIVE POOL AS PER PUBLISHED A/C UPTO 22.05.11.
AS ON 31.05.11**

Figures in Rs

CONSTITUENTS	2003-04		2004-05		2005-06		2006-07		2007-08		2008-09		2009-10		2010-11		2011-12		TOTAL	
	RECEIVABLE	RECEIVED	RECEIVABLE	RECEIVED	RECEIVABLE	RECEIVED	RECEIVABLE	RECEIVED	RECEIVABLE	RECEIVED	RECEIVABLE	RECEIVED	RECEIVABLE	RECEIVED	RECEIVABLE	RECEIVED	RECEIVABLE	RECEIVED	RECEIVABLE	RECEIVED
BSEB	0	0	0	0	0	0	284950	0	0	0	0	0	0	0	0	0	0	0	284950	0
DVC	6593	6593	86391	86391	264138	264138	0	0	0	0	0	0	0	0	0	0	0	0	357122	357122
GRIDCO	0	0	0	0	0	0	0	0	0	0	223311	223311	0	0	0	0	0	0	223311	223311
WBSEB	1778848	1778848	451090	451090	350045	350045	3519490	3519490	881058	881058	3716019	3716019	3431470	3431470	1273089	1273089	0	0	15401109	15401109
UPPCL	0	0	0	0	0	0	28575	8465	0	0	0	0	0	0	0	0	0	0	28575	8465
TOTAL	1785441	1785441	537481	537481	614183	614183	3833015	3527955	881058	881058	3939330	3939330	3431470	3431470	1273089	1273089	0	0	16295067	15990007

Total Received 16274957

Expenditure incurred for organising workshop on Black Start Procedure (4 SLDCs) 160000

Expenditure incurred for organising a seminar on Power Exchange 290000

Expenditure incurred for organising seminar on "Reduction of Agreed technical & commercial Loss-Issues and Challenges " at Bhubaneswar 184991

Expenditure incurred for organising workshop on Black Start Procedure at ERPC on 19.11.09 123028

Expenditure incurred for organising a seminar on Black Start on 18.04.09 at Hotel Big Boss 49050

Amount Retained in Reactive A/C 15467888

Waival of UPPCL amount on 14 th commercial sub committee meeting on 10.09.10 20110

Amount Credited to reactive account due to TDS (2003-04 to 2007-08) on 25.11.10 402619

Expenditure for SCADA Training at ERLDC ON 23.02.11 226115

Net Retained in Reactive A/C 15624282

Proposed Expenditure for EMS training approved in 13th ERPC meeting 3409885

Proposed Workshop/Seminar on Transmission pricing, Power Exchange & FGMO 2000000

Estimated Available Amount in the POOL 10214397

ANNEXURE-IV

DETAILS OF DISBURSEMENT TO POWER SYSTEM DEVELOPMENT FUND

SI No	Nature of Amount	Amount transferred to PSDF	Date of Disbursement	Cheque No	Remarks
1	UI (Principal)	4976.07019	11.11.10	219865 to 219891	Capping of 2007 - 08
	UI (Principal)	12153.10284	11.11.10	219865 to 219891	Capping of 2008 - 09
	UI (Principal)	3430.79751	11.11.10	219865 to 219891	Capping of 2009 - 10
	UI (Principal)	3836.50702	11.11.10	219865 to 219891	Surcharge of 2009 - 10
	UI (Principal)	975.41106	11.11.10	219865 to 219891	Capping of 2010 - 11
	UI (Principal)	1314.55152	11.11.10	219865 to 219891	Surcharge of 2010 - 11
	Total	26686.44014			
2	UI (Interest)	1284.96601	19.11.10	219919 & 219920	Bank interest of 2009 - 10
3	UI (Principal)	581.47030	22.02.11	219990	Capping & Surcharge
4	UI (Principal)	487.14040	14.03.11	220021	Capping & Surcharge
5	UI (Interest)	200.00000	14.03.11	220021	Bank Interest for UI of 2010-11
6	Reactive (Interest)	6.16992	14.03.11	220021	Bank Interest for Reactive of 2010-11
7	UI (Principal)	202.29434	20.05.11	No Cheque	Capping of 2010 - 11
8	UI (Principal)	204.06337	20.05.11	No Cheque	Surcharge of 2010 - 11
	Total	29652.54448			

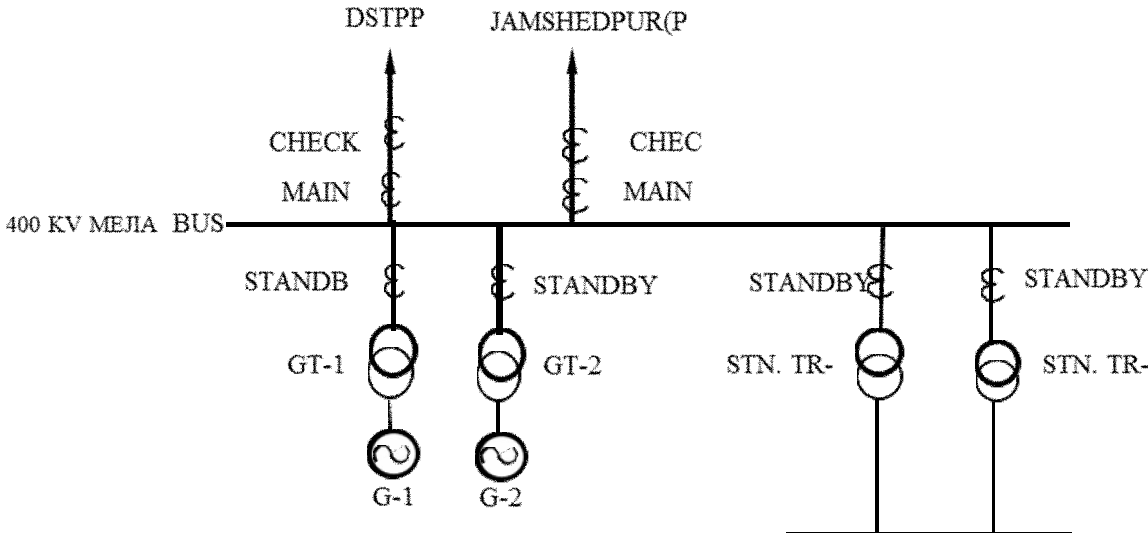

ANNEXURE-VI

2010-11: Letter of Credit (LC) Amount against UI charges*Figures in Lacs of Rupees*

ER Constituents	Total UI charges payable to pool during 2010-11 (A)	Average weekly UI liability (A)/52 weeks (B)	LC Amount 110% of (B)
BSEB	6590.62	126.74	139.42
JSEB	2951.66	56.76	62.44

Annexure-VII

A) 400kV D/C Koderma -Biharshariff Transmission Line and associated bays at Biharshariff.

DOCO	6/1/2011
Name of Project	DVC Start –UP Power
Approved Cost	290.49 Cr.
Standing Committee-ER reference	05/05/2007 at Puri & 05/11/2007 at Ranchi
EREB/ERPC Meeting reference	3 rd TCC and 4 th ERPC at Ranchi Dated 18/06/07 & 19/06/07.
Sharing of Transmission Charge	To be borne by DVC till the time the same is paid by respective beneficiaries.

B) 160 MVA 220/132kV ICT-II and associated 220kV & 132kV bays at Baripada.

DOCO	4/1/2011
Name of Project	Eastern Region Strengthening Scheme-II.
Approved Cost	227.52 Cr.
Standing Committee-ER reference	26/06/2006 Mirik, Darjeeling
EREB/ERPC Meeting reference	1 st TCC and 2 nd ERPC at Kolkata Dated 28/08/06 & 29/08/06.
Sharing of Transmission Charge	* To be borne by GRIDCO as per CERC Regulation 200-14 clause (5 of 33)

* Transmission charges for 400/220kV Step-Down (ICTS) and downstream systems, under inter state transmission scheme brought under commercial operation after 28/03/2008 shall be determined separately and shall be payable only the beneficiaries directly served.

**List of participants in the 17th Sub-Committee meeting held on
16.06.2011 at ERPC, Kolkata**

Name of the Constituent / Organisation	Name S/Shri	Designation
JSEB	S.C.MISHRA	CE
WBSEDCL	A.PRADHAN	Divisional Engineer
	M.S.PAL	Chief Engineer (PTR)
DVC	C.KARMAKAR	
	S.GHOSAL	
GRIDCO	P.K.PRADHAN	Director (Comml)
	S.K.MOHANTY	Manager
	Mrs. M.MISHRA	Dy. Manager
	N.KHAN	Liaison Officer
OPTCL	P.K.PANDA	Manager
GOVT. OF SIKKIM	H.B.PRADHAN	
NHPC	N.A.KUMAR	
POWERGRID	R.KUMAR	Sr. Engineer
	A.K.VERMA	
NTPC	A.K.JUNEJA	Addl. General Manager
	K.K.SINHA	Addl. General Manager
	P.K.GHOSAL	Dy. General Manager
ERLDC	P. PENTAYYA	General Manager , POSOCO
	P.MUKHERJEE	Dy. General Manager
	D.K.SRIVASTAVA	Dy. General Manager
	G.CHAKRABORTY	
	N.AHMAD	Sr. Engineer
	P.S.DAS	Manager
STERLITE ENERGY LTD.	M.RASTOGI	AVP (Power)
	M.PANDA	
	P.MAHAPATRA	
CYBUZZSC	KUMAR RAVI	
ERPC	A.K.RAMPAL	Member Secretary
	A.K. BANDYOPADHYAY	Superintending Engineer (Oprn.)
	J. BANDYOPADHYAY	Superintending Engineer (Comml.)
	B.SARKHEL	Superintending Engineer (PS)
	S.P.DATTA	Dy. General Manager (NTPC)
	V.KALYANRAMAN	Executive Engineer
	S.M.JHA	Executive Engineer
	G.GHOSH	Executive Engineer
S.PAUL	Executive Engineer	